

**CHAPTER 2025-2**

No. 35      **AN ORDINANCE ESTABLISHING A TAX STABILIZATION AGREEMENT FOR 241 POCASSET AVENUE**

Approved January 22, 2025

*Be it ordained by the City of Providence:*

WHEREAS, Maxton Investments LLC (“Project Owner”) is the owner of certain real property located in the City at 241 Pocasset Avenue, Providence, Rhode Island 02909, Assessor’s Plat 109, Lot 202; and

WHEREAS, Project Owner has proposed and committed to construct a new construction of an eight (8) unit residential building consisting of three 2-bedroom units and five 1-bedroom units with a projected cost of \$829,440.00 to construct; and

WHEREAS, Pursuant to Rhode Island General Laws (R.I.G.L.) § 44-3-9, the General Assembly has authorized the City of Providence, acting through its City Council and subject to certain enumerated conditions, to exempt or determine a stabilized amount of taxes to be paid on account of real and personal property for a period not to exceed twenty (20) years; and

WHEREAS, Pursuant to the Providence Code of Ordinances, as amended, specifically Chapter 21, Article XVIII, the granting of the tax stabilization will inure to the benefit of the City of Providence and its residents by reason of:

The willingness of Project Owner to construct new or to replace, reconstruct, convert, expand, retain, or remodel buildings, facilities, fixtures, machinery, or equipment, resulting in an increase or maintenance in plant, residential housing, or commercial building investment by the Project Owner.

NOW, THEREFORE, In consideration of the mutual agreements and promises set forth herein and other good and lawful consideration the receipt of which is hereby acknowledged, the parties agree as follows:

**SECTION 1.      DEFINITIONS.**

“Property” shall mean certain real property together with any and all buildings, structures, and/or improvements now or in the future located in the City at 241 Pocasset Avenue, Providence, Rhode Island 02909, Assessor’s Plat 109, Lot 202;

“Property Owner” shall mean any entity with a recorded legal or equitable right and/or interest in and/or to the Property, including any and all successors and assigns.

**SECTION 2.      TAX STABILIZATION.**

Section 2.1. Grant. The City, in accordance with R.I.G.L. § 44-3-9 and the City of Providence Code of Ordinances, does hereby grant a five-year tax stabilization in favor of the Property Owner with respect to the Property.

Section 2.2. Term. The tax stabilization term (“Term”) shall be the period commencing on December 31, 2024 and terminating on December 31, 2030. (Tax Years 2025-2030).

Section 2.3. Plan. During the Term, the stabilized amount of taxes to be paid by the Property Owner with respect to the Property, notwithstanding the valuation of the Property or the then-current rate of tax, is as follows: for the first tax year of the stabilization term, the Property owner shall make a tax payment equal to the then-current assessment of \$84,400.00 set by the Tax Assessor (“Base Assessment”) multiplied by the then-current tax rate (hereinafter the “Base Assessment Tax”). The total base tax amount of the then-current tax rate is equal to \$2,962.44. For each tax year thereafter, the Property Owner will pay the Base Assessment Tax plus a percentage of the taxes due and owing on the difference between the Base Assessment and then-current assessed value of the Property multiplied by the then-current rate. See “TSA Projection 241 Pocasset” incorporated herein as if fully reproduced and attached hereto and as Exhibit A.

Section 2.4. Payment Deadlines. During the Term and in accordance with the tax stabilization plan outlined therein, stabilized tax payments shall be made in either a lump sum during the first quarter of the applicable tax year or in equal quarterly installments at the discretion of the Property Owner. If the Property Owner elects to make quarterly installments, each quarterly installment shall be due on the same date that quarterly taxes are due for all other taxpayers in the City of Providence.

Section 2.5. Obligation of Property Owner to Make Payment. During the Term and in accordance with the tax stabilization plan outlined herein, stabilized tax payments shall be an obligation of the Property Owner.

Section 2.6. Non-Receipt of Stabilized Tax Bill. Failure by the City to send or failure by the Property Owner to receive a stabilized tax bill does not excuse the nonpayment of the stabilized tax nor affect its validity or any action or proceeding for the collection of the tax in accordance with this stabilization, an Agreement formed hereunder, or otherwise.

Section 2.7. Recording of Plan, Running with Land. The Property Owner shall cause this tax stabilization plan to be recorded at its expense in the City’s official public land evidence records. This recording shall be construed to provide a complete additional alternative method under contract law for the securitization of payments due and owing under this stabilization and shall be regarded as supplemental and in addition to the powers conferred by other state and local laws.

### SECTION 3. ADDITIONAL REQUIREMENTS OF STABILIZED PROJECTS.

Section 3.1. Commencement of Performance. Construction or rehabilitation shall commence within twelve (12) months, and shall obtain a Certificate of Occupancy from the Department of Inspections and Standards within thirty-six (36) months of the effective date of said agreement. Property Owners who fail to meet either of these deadlines will be required to retroactively pay the difference between their actual stabilized tax payments and what they would have paid if ineligible for the specified tax considerations. The owner may, twelve (12) months prior to the applicable deadline, submit a request to the city council for approval of an extension to such applicable deadline.

Section 3.2. Permits and Certificates of Occupancy. Property Owner shall obtain all permits and certificates of occupancy as required by state and local law in connection with any and all intended construction or rehabilitation.

Section 3.3. MBE/WBE. During the Term, the Property Owner shall comply with any and all requirements under Chapter 21, Article II, Section 52 of the Providence Code of Ordinances as it pertains to Minority and Women Business Enterprises.

Section 3.4. Internal Revenue Service reporting. Except as provided under R.I.G.L. § 28-42-8, any person performing services at the Property shall annually receive either a W-2 statement or an IRS Form 1099.

Section 3.5. First Source. During the Term, the Property Owner shall enter into a First Source Agreement with the Director of First Source Providence in accordance with Chapter 21 Article III1/2 of the Providence Code of Ordinances, including at least one percent (1%) of the total amount of discounted taxes to be directed to the first source trust fund, per Section 21-95.

Section 3.6. Equal Employment. During the Term, the Property Owner shall work with the City's Office of Human Resources, Division of Equal Employment Opportunity to ensure the City's goals to prohibit discrimination against qualified individuals based on their status as protected veterans or individuals with disabilities, and prohibit discrimination against all individuals based on their race, color, religion, sex, sexual orientation, gender identity or national origin are met. Moreover, the Property Owner will take affirmative action to employ and advance in employment individuals without regard to race, color, religion, sex, sexual orientation, gender identity, national origin, protected veteran status or disability.

Section 3.7. "Buy Providence" Initiative. During the Term, the Property Owner shall use best efforts to ensure that construction materials are purchased from economically competitive and qualified vendors located in the city of Providence. In furtherance of this effort, the Property Owner will work with the city to develop a list of Providence vendors and subcontractors in order to create a preferred vendor list of qualified and economically competitive vendors for the construction of the project. Furthermore, once the Property Owner constructs the development, the Property Owner will use good faith efforts to conduct ongoing business with and provide preference to economically competitive and qualified Providence businesses.

Section 3.8. Apprenticeship. OMITTED

Section 3.9. Project Compliance. This stabilization shall in no way confer that the underlying project (construction or rehabilitation) is either compliant with the Providence Zoning Ordinance or has received the necessary approvals from any board or commission, including (but not limited to) the Historic District Commission, the Downtown Design Review Committee, the Capital Center Commission, the City Plan Commission, the Zoning Board of Review, or the I-195 Redevelopment Commission (as applicable).

Section 3.10. Prohibited and Restricted Uses. The following uses, as defined by Chapter 27 of the Providence Code of Ordinances, shall not be permitted on the Property during the Term: Adult use (including adult bookstore/retail, adult arcade, adult cabaret, adult motion picture theater, and adult hotel/motel), compassion center or cultivation center, contractor storage yard, fraternity or sorority, landfill, materials processing of scrap metal, storage yard (outdoor), and the retail use for gun stores, payday lending, or check-cashing operations. The following uses, as defined by Chapter 27 of the Providence Code of Ordinances, shall not exceed twenty-five percent (25%) of the usable square footage of the Property during the Term: bar, nightclub, and retail sales of alcohol.

Section 3.11. City of Providence Parks and Recreation Trust Fund. The Property Owner shall make annual payments to the Fund in the amount of seven percent (7%) of the estimated total of taxes abated (as shown in the Tax Assessor's Fiscal Note) amortized over the Term. Said annual payments will be payable within thirty (30) days of receipt of an invoice for the same from the Office of the Tax Assessor. If, for any reason, this Ordinance is retroactively revoked, payments to the fund shall remain and will not be forfeited due to a default.

Section 3.12 Payment of Area Standard Wages. OMITTED

Section 3.13 Post-Construction Jobs. OMITTED

Section 3.14. Monitoring Fee. Within thirty (30) days of receiving a statement from the Tax Assessor, the Property Owner shall remit a monitoring/compliance fee to the City in the amount of 0.01 percent of the total project costs as presented in the Property Owner's application for each respective tax year during the term of this stabilization.

## SECTION 4. TRANSFER OF PROPERTY.

Section 4.1. Transfer Generally. Stabilized tax payments shall be an obligation of the Property Owner during any of the tax stabilization terms as defined in Section 2 above and in accordance with the tax stabilization plan outlined therein, without regard to any transfer of the Property. Additionally, in accordance with Section 2.7, the burdens and benefits of this stabilization will run with the land, and as for payment of taxes shall run in favor of the City regardless of any transfer of ownership. The Property Owner must provide prior written notice to the City before any transfer of the Property so that the City may determine, in its sole discretion, as to whether or not this stabilization will continue.

Section 4.2. Transfer to Tax Exempt Entities. In the event that the Property Owner transfers the Property to a tax-exempt entity, this stabilization shall be void ab initio and any entity holding an equitable or legal interest in the Property on or after the effective date of this stabilization shall be jointly and severally liable for the full taxes due and owing from said effective date forward.

Section 4.3. Post-Expiration Transfers. In the event that the Property Owner transfers the Property to a tax-exempt entity within five years from the end of any tax stabilization term, as defined in Section 2.2 above, any and all Property Owners will pay the following: five percent (5%) of the sale price in said transfer if sold to a tax-exempt entity in the first year following the end of the term; four percent (4%) of the sale price in said transfer if sold to a tax-exempt entity in the second year following the end of the term; three percent (3%) of the sale price in said transfer if sold to a tax-exempt entity in the third year following the end of the term; two percent (2%) of the sale price in said transfer if sold to a tax-exempt entity in the fourth year following the end of the term; and one percent (1%) of the sale price in said transfer if sold to a tax-exempt entity in the fifth year following the end of the term.

## SECTION 5. ANNUAL PROGRESS REPORT.

Section 5.1. Reporting Generally. The Property Owner shall provide monthly reports to the City Council, or the Council's designee, and in such instance that the Property is within the jurisdiction of the I-195 Commission then the Commission as well, on its progress in complying with the provisions of this stabilization.

Section 5.2. Reporting Requirements. The reporting format shall be provided by the City Council of Providence in its sole discretion to document construction-based employment information and demographics related to the terms of this stabilization. If the Property Owner, its developer and/or other person/entity authorized by the Property Owner, does not timely submit their monthly reports to the City Council, or its designee, the City Council or its designee shall notify the Property Owner. The Property Owner shall have ten (10) days thereafter to provide the information to the City or its designee. The project site owner, the Director of Planning and Development, the Director of First Source, and a representative of the third-party entity monitoring apprenticeship requirements shall annually report to the City Council on progress in complying with the provisions of this stabilization, including but not limited to, sections 2 and 3. Specifically, its report shall include a performance report on construction or rehabilitation with evidence of final construction costs, status of stabilized tax payments, and evidence of compliance with Section 3. Upon receipt and review, the City Council may require and request additional information.

## SECTION 6. DEFAULT.

The following events shall constitute an event of default:

- (A) Failure of the Property Owner to pay any amount due under or with respect to Section 2; or
- (B) Failure of the Property Owner to record a Notice of this stabilization as required by and in accordance with Section 2; or
- (C) Failure of the Property Owner to meet any of the performance obligations set forth in Section 3; or

- (D) Failure of the Property Owner to annually report as required by Section 5; or
- (E) Failure of the Property Owner to notify the City in writing within thirty (30) days of the transfer of the Property; or
- (F) Transfer of the Property by the Property Owner outside of the terms of this stabilization; or
- (G) Failure of the Property Owner to comply with any other obligation or promise contained within any section or subsection of this stabilization; or
- (H) Failure of the Property Owner to comply with all state and local law regarding building and property maintenance codes, zoning ordinances, and building and/or trade permits; or
- (I) Failure of the Property Owner to waive as set forth in Section 8.4; or
- (J) Failure of the Property Owner to remain current on any and all other financial obligations to the City of Providence.

#### SECTION 7. NOTICE AND CURE.

Section 7.1. Notice and Cure Period. In event of potential Default (as defined in Section 6), the City Solicitor (City Council designee) shall provide written notice to the Property Owner of such potential Event of Default (“First Notice”) and notify the Property Owner that it shall have sixty (60) days, from the date the Notice herein is sent, to cure any Event of Default pursuant to this stabilization (“Initial Cure Period”). If said Event of Default is not cured within the Initial Cure Period, then the City Solicitor (or City Council designee) shall notify the Property Owner in writing (“Second Notice”) that this stabilization is terminated and that a bill will be sent out by the Tax Assessor sixty (60) days from the date of the Second Notice. Said bill will be for the abated taxes to date and those amounts including, but not limited to, any amounts of taxes due and owing but not paid, interest, penalties, assessments, and fees associated therewith (“Delinquency Bill”).

The Property Owner may petition the City Council in writing for additional time beyond the Initial Cure Period in order to cure any alleged Event of Default (“Extended Cure Period”). Once filed with the City Clerk, a petition requesting an Extended Cure Period will toll the time period between the Second Notice and the issuance of the Delinquency Bill until the petition is either approved, denied, or withdrawn. An indefinite continuance shall constitute a denial.

Section 7.2. Agreed Upon Address for Purposes of Written Notice. All notices, requests, consents, approvals, and any other communication which may be or are required to be served or given (including changes of address for purposes of notice) shall be in writing and shall be sent registered or certified mail, or by nationally recognized overnight courier (such as Federal Express or UPS) and addressed to the following parties set forth below:

If to:                   City of Providence  
                               Office of the City Clerk  
                               25 Dorrance St.  
                               Providence, RI 02903

If to:                   Maxton Investments LLC  
                               166 Valley Street, Bldg. 6M, Suite 103  
                               Providence, RI 02909

SECTION 8. RIGHTS AND REMEDIES.

Section 8.1. Collection of Taxes. At any time during the Term, the City of Providence may pursue any and all rights and remedies arising under any state or local law, including but not limited to R.I.G.L. Chapters 7-9 of Title 44, and/or arising under this stabilization to collect stabilized taxes due and owing in accordance with the tax stabilization plan and/or to collect any retroactive taxes.

Section 8.2. City's Lien Remedies and Rights. Nothing herein contained shall restrict or limit the City's rights and/or remedies with respect to its first priority lien for taxes as provided under Title 44 of the General Laws. Rather, this stabilization shall be construed to provide a complete additional alternative method under contract law for the collection of taxes, and shall be regarded as supplemental and in addition to the powers conferred by other state and local laws.

Section 8.3. Waiver. Failure or delay on the part of the City to exercise any rights or remedies, powers or privileges at any time under this stabilization or under any state or local law shall not constitute a waiver thereof, nor shall a single or partial exercise thereof preclude any other or further exercise thereof or the exercise of any other right, remedy, power of privilege thereunder.

Section 8.4. Property Owner's Rights. During the tax stabilization term as defined in Section 2.2, the Property Owner agrees to waive and forever forgo any and all of its rights and privileges under R.I.G.L. § 44-5-26 and -27, as it pertains to the Tax Payments due and owing pursuant to this stabilization, unless there is a loss of use of the Property as a result of fire, flood, earthquake, or other act of God. Nothing herein shall be construed to limit the right of the Property Owner to pursue its rights and remedies under the terms of this stabilization.

SECTION 9. MISCELLANEOUS TERMS.

Section 9.1 Severability. The sections of this stabilization are severable, and if any of its sections or subsections shall be held unenforceable by any court of competent jurisdiction, the decision of the court shall not affect or impair any of the remaining sections or subsections.

Section 9.2. Applicable Law. This stabilization shall be construed under the laws of the State of Rhode Island, the City of Providence Home Rule Charter, and the City of Providence Code of Ordinances, as amended.

Section 9.3. Entire Agreement; Amendments. This stabilization and all attachments, addenda, and/or exhibits attached hereto shall represent the entire agreement between City and the Property Owner. This stabilization shall not be modified, amended, extended or altered in any way by oral representations made before or after the execution of this stabilization. Any and all modifications, amendments, extensions or alterations must be in writing duly executed by all parties, and passed by City Council.

Section 9.4. Effective Date. This stabilization shall take effect upon passage of this Ordinance by the Providence City Council, approval by the Mayor (or the Ordinance otherwise becoming effective). Immediately following the Effective Date, the Property Owner shall record this Ordinance with the City's official public land evidence records

IN CITY COUNCIL  
JAN 09 2025  
FIRST READING  
READ AND PASSED

Jina L. Mastrosianni  
CLERK

IN CITY  
COUNCIL  
JAN 16 2025  
FINAL READING  
READ AND PASSED

Rachel M. Miller  
RACHEL M. MILLER, PRESIDENT  
Jina L. Mastrosianni  
CLERK

I HEREBY APPROVE.

Brett P. Smith  
Mayor

Date: 1/22/25

**Exhibit A**

5 Year TSA (6 Projection)  
 241 Pocasset St  
 Plat 109 Lot 202

Tax Year	Year	Value	Base Tax +		Base Tax	Phased-In Tax	Proposed Total Tax	Payments at Full Taxation
			% of Incr.	Tax Rate				
2025	1	84,400	Base Tax	\$35.10	\$2,962.44	\$0	\$2,962.44	\$ 2,962.44
2026	2	1,000,000	Base + 20%	\$35.10	\$2,962.44	\$6,427.51	\$9,389.95	\$ 35,100.00
2027	3	1,000,000	Base + 40%	\$35.10	\$2,962.44	\$12,855.02	\$15,817.46	\$ 35,100.00
2028	4	1,030,000	Base + 60%	\$35.10	\$2,962.44	\$19,914.34	\$22,876.78	\$ 36,153.00
2029	5	1,030,000	Base + 80%	\$35.10	\$2,962.44	\$26,552.45	\$29,514.89	\$ 36,153.00
2030	6	1,030,000	Full Vale	\$35.10			\$36,153.00	\$ 36,153.00

Savings to applicant:

\$116,714.52
\$ 181,621.44  
↓
↙  
\$ 64,906.92

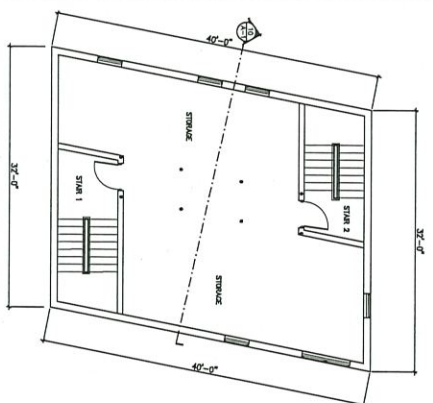

1. BASEMENT PLAN  
A.1 SCALE: 1/8" = 1'-0"

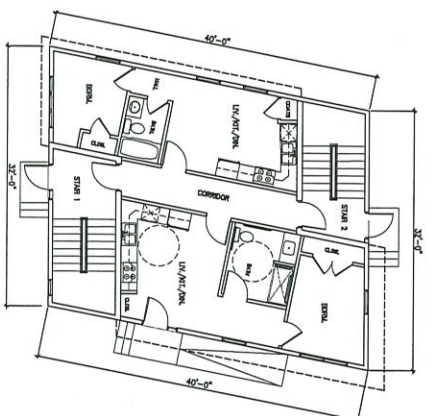

2. FIRST FLOOR PLAN  
A.1 SCALE: 1/8" = 1'-0" 1,255 SF.

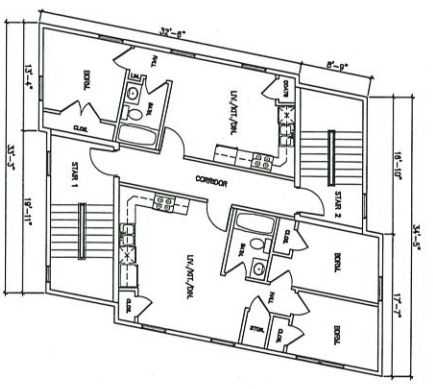

3. SECOND & THIRD FLOOR PLAN  
A.1 SCALE: 1/8" = 1'-0" 1,399 SF. / FL.

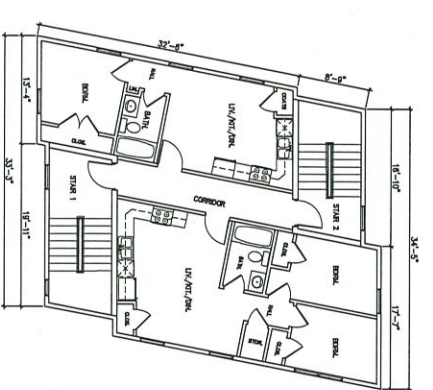

4. FOURTH FLOOR PLAN  
A.1 SCALE: 1/8" = 1'-0" 1,399 SF.



5. SITE PLAN  
A.1 SCALE: 1" = 30'

SEE SIGNED (BY CONTRACTOR) FOR FINAL LOT DIMENSIONS, BUILDING SIZE & LAYOUT

[241 POCASSET AVENUE] [Table 5-1]

A.P.	REQUIRED	PROPOSED	ENDORSED
LOT:	109	202	
ZONE:	C-1	202	
TOTAL LOT AREA:	2,224 SF.	448K	OK
MAX. TOTAL BUILD COVERAGE:	NONE	43.3%	OK
MAX. HEIGHT (STORIES):	45'	0' & 10"	OK
SIDE YARDS:	NONE	12.8'	OK
FRONT YARD SETBACK:	0' & 5"	5' & 3.8'	OK
MAX. PARKING (TOTAL):	NONE	---	OK
TRAILER PARKING (TOTAL):	15K	15K	OK
PARKING COAL:	0	0	OK

**FRONT FACADE TRANSPARENT/OPACIT. ANAL.**

GROUND F.L.	MULTI-FAMILY (50% GLASS)	15%	15.0%	OK
TOTAL AREA = 3764' (4.5) = 564'				
Windows + Doors = 2844(28) = 624' (OK)				
Transparency = 61/27(40) = 124% (OK)				
Walls = 14(1)-21.6 = 106.64'				
Transparency = 103.6/850(100) = 12.4% (OK)				

**FRONT FACADE TRANSPARENT/OPACIT. ANAL.**

GROUND F.L.	MULTI-FAMILY (50% GLASS)	15%	15.0%	OK
TOTAL AREA = 4704' (4.5) = 70.54'				
Windows + Doors = 115.5(47)(100) = 15K (OK)				
Transparency = 115.5/770(100) = 15%				
Walls = 14(1)-21.6 = 106.64'				
Transparency = 103.6/1024(100) = 10.1%				
Walls = 14(1)-21.6 = 106.64'				
Transparency = 103.6/1024(100) = 10.1%				

**THE CANOPY (150% GLASS)**

2.5204' (15%) = 378' (LONGWOOD) = 700	15%	27.7%	OK
700/2524(100) = 27.7%			

**PRELIMINARY FOR REVIEW ONLY**  
4/15/2024

INCORPORATED  
DATE: 4/15/2024  
DRAWN BY: [Signature]  
CHECKED BY: [Signature]

**mag associates inc.**  
architectural planning + interior  
51 Point Street  
East Providence, RI 02914  
Tel: 401-453-8800  
magassociates@proton.com



e.a. design ltd.  
570 Broad Street  
Providence, RI 02903  
401-550-8800

BUILDING:  Proposed  
MECHANICAL:  Addition

A.P. 109, LOT 202  
241 POCASSET AVE.  
PROVIDENCE, RI.

Scale: AS NOTED  
Design: M.E.E.  
Drawn: M.E.E.  
Checked: A.M.  
Date: 4-14-2024

Per:  CONSTRUCTION  
 PERMIT  
 REVIEW ONLY  
 OTHER

**A-1**

SITE PLAN & CODE ANALYSIS  
TYPICAL SECTION  
CODE ANALYSIS  
EXTERIOR ELEVATIONS

FILE: PROCASSSET\_P01 Prelim A-1-1a.rvt

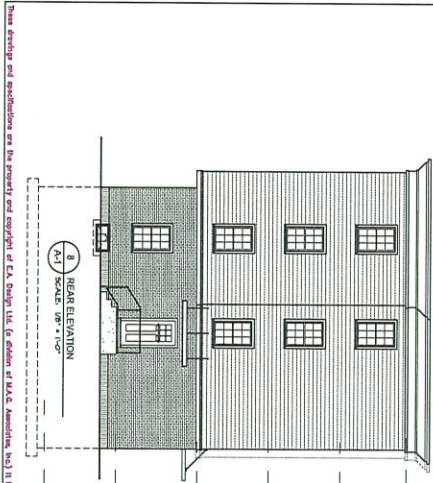

8. REAR ELEVATION  
A.1 SCALE: 1/8" = 1'-0"

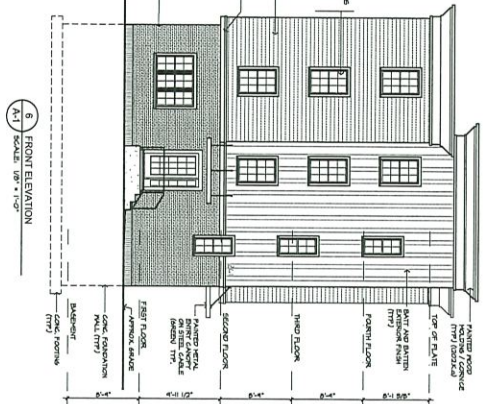

6. FRONT ELEVATION  
A.1 SCALE: 1/8" = 1'-0"

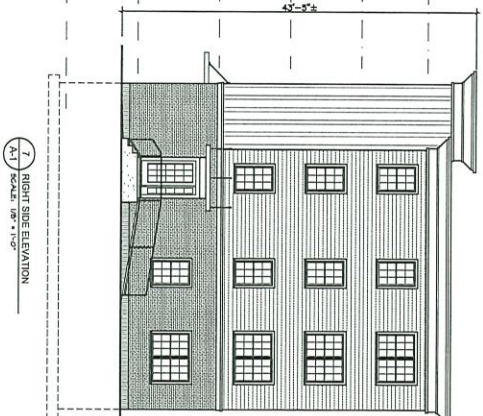

7. RIGHT SIDE ELEVATION  
A.1 SCALE: 1/8" = 1'-0"

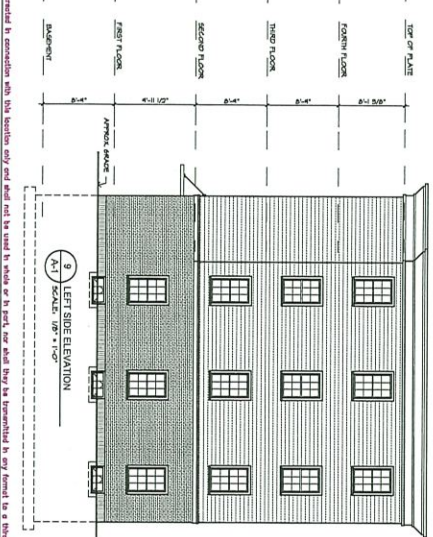

9. LEFT SIDE ELEVATION  
A.1 SCALE: 1/8" = 1'-0"

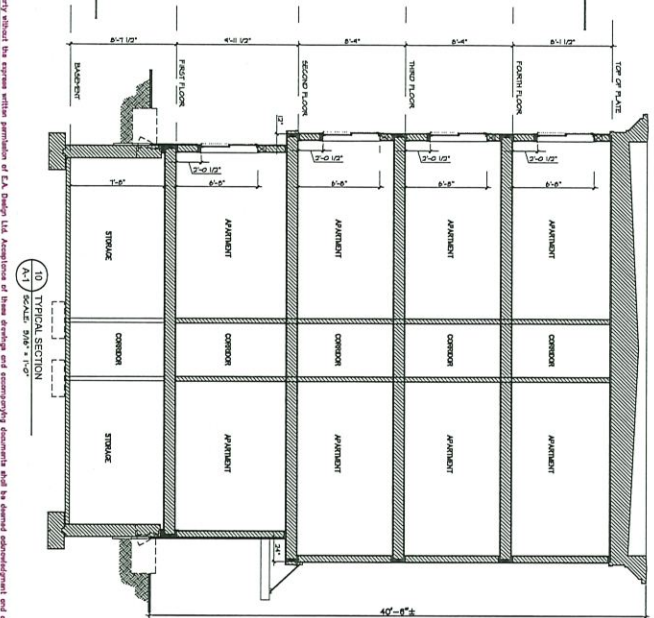

10. TYPICAL SECTION  
A.1 SCALE: 3/8" = 1'-0"

These drawings and specifications are the property and copyright of E.A. Design, LLC. If copies of this drawing are made, they shall be made in whole or in part, and shall be held to be the property of E.A. Design, LLC. Any reproduction in any form without the express written permission of E.A. Design, LLC. Assumption of these drawings and specifications documents shall be deemed acknowledgment and acceptance of these terms and conditions.



